

ROCK GRAPPLES

360-Degree Rotation

High torque, heavy duty, continuous 360-degree standard power rotation.

High Pressure Rotary Union

Reduces back pressure and extends seal life.

High Pressure Hydraulic Cylinders

Features thick barrel walls, large ports and bolt-on cylinder heads for easier maintenance.

Cylinder Shrouds

Protects cylinder walls and reduces material packing.

PINS and BUSHINGS

Large diameter and heat treated steel for extended wear life.

Heavy Duty Tines

Features boxed tine sections, face plate support gusset and heavy duty abrasion resistant faceplate.

Weld-On Leg Tips

Designed to be durable and replaceable.

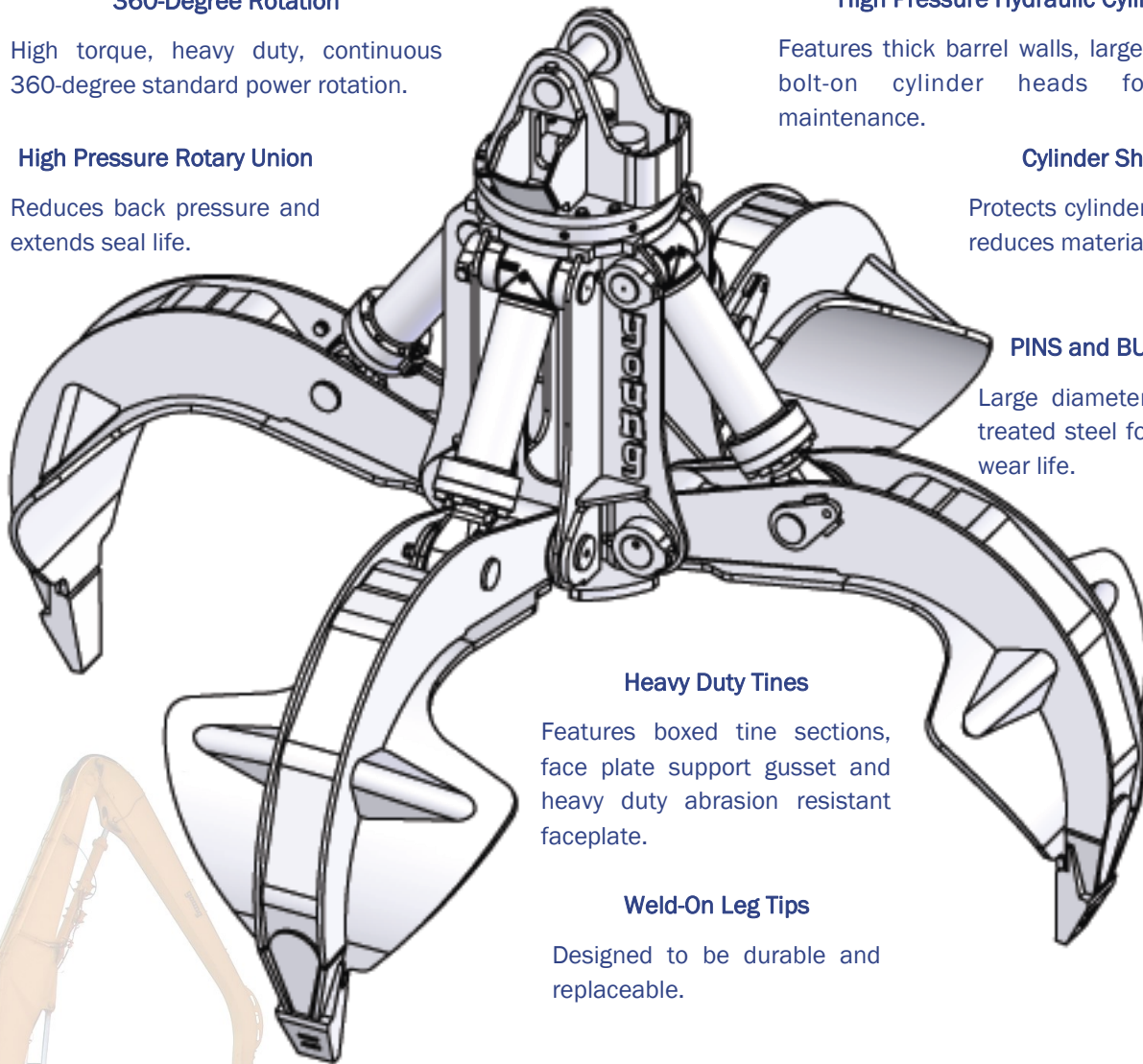

Max Machine Weight		135,000 lbs.		200,000 lbs.	
Model		LR150C	LR200C	LR300C	LR400C
Capacity		1 1/2 cu yd	2 cu yd	3 cu yd	4 cu yd
Tool Weight		5500 lbs.	6900 lbs.	10,850 lbs.	11,600 lbs.
Max Opening	A	101 1/4 in	109 in	129 in	139 1/2 in
Overall Height - Open	B	79 1/2 in	85 3/4 in	104 1/4 in	107 1/4 in
Overall Height - Closed	C	98 1/4 in	106 3/4 in	128 in	134 in
Overall Width - Closed	D	68 3/4 in	74 in	86 1/2 in	92 1/2 in
Mounting PIN Diameter	E	3 in	3 in	4 in	4 in
Crosshead Width	F	6 7/8 in	6 7/8 in	8 1/4 in	8 1/4 in
Tine Separation	G	97 3/4 in	105 1/2 in	117 1/2 in	131 1/4 in

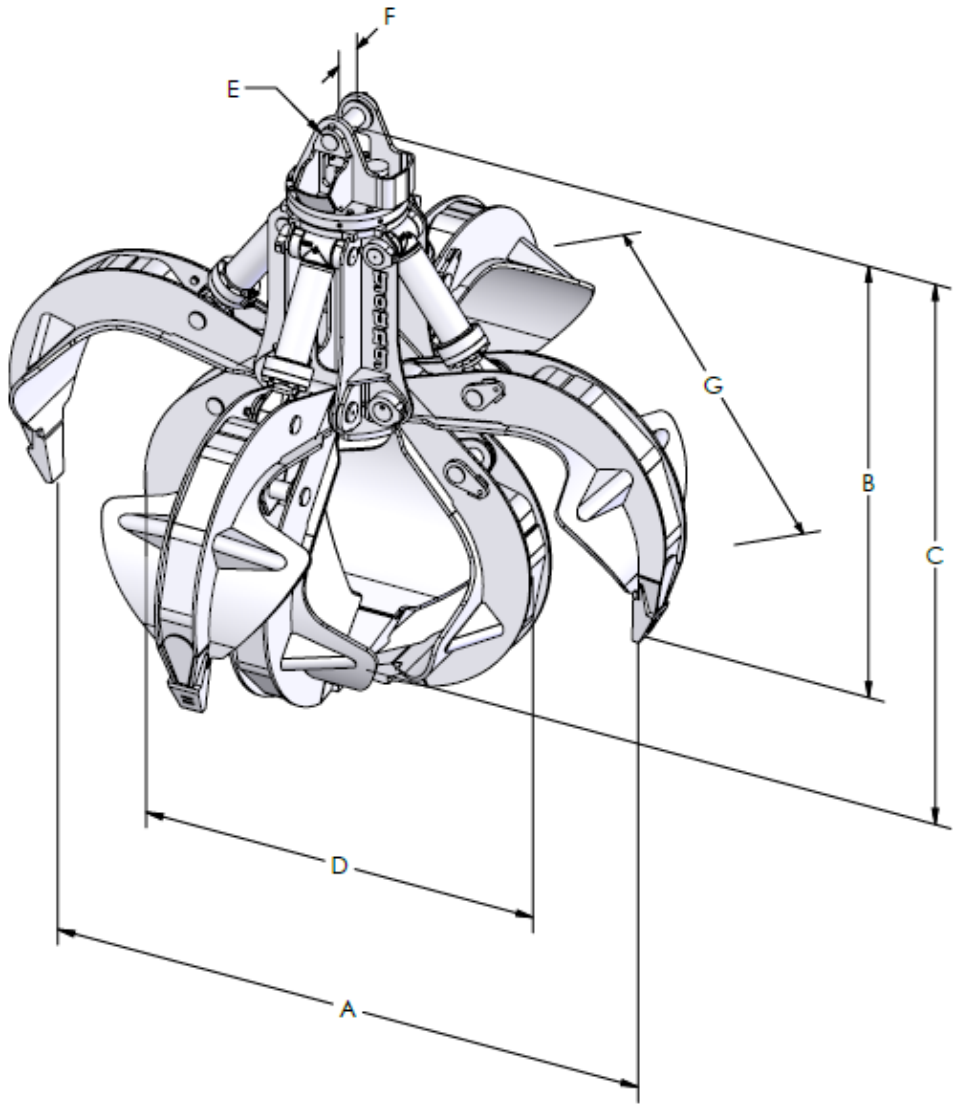

www.youngcorp.com

find us on [facebook](#)