

360-Degree Power Rotation

High torque, heavy duty and continuous.

High Pressure Rotary Union

Reduces back pressure and extends seal life.

Weld-On Leg Tips

Designed to be durable and replaceable.

High Pressure Hydraulic Cylinders

Features thick barrel walls, large ports and bolt-on cylinder heads for easier maintenance.

Cylinder Shrouds

Protects cylinder walls and reduces material packing.

PINS and BUSHINGS

Large diameter and heat treated steel for extended wear life.



4-TINE SCRAP GRAPPLES

Max Machine Weight	65,000 lbs.			135,000 lbs.					
Model	LO-50D	LO-75D	LO-95D	LO-100D	LO-125D	LO-150D	LO-200D	LO-250D	
Capacity	1/2 cu yd	3/4 cu yd	1 cu yd	1 cu yd	1 1/4 cu yd	1 1/2 cu yd	2 cu yd	2 1/2 cu yd	
Tool Weight	2865 lbs.	3025 lbs.	3200 lbs.	4740 lbs.	4910 lbs.	5080 lbs.	5380 lbs.	5680 lbs.	
Max Opening	A	70 5/8 in	79 1/4 in	88 3/4 in	86 1/2 in	93 in	98 5/8 in	109 in	117 5/8 in
Open Overall Height	B	75 1/4 in	77 3/4 in	80 1/2 in	83 7/8 in	85 3/4 in	87 3/8 in	90 3/8 in	92 7/8 in
Closed Overall Height	C	85 5/8 in	90 5/8 in	96 1/8 in	97 in	100 3/4 in	104 in	110 in	115 in
Closed Overall Width	D	51 1/4 in	55 3/4 in	60 1/2 in	63 1/4 in	66 3/8 in	69 1/8 in	74 1/4 in	79 in
Spindle Pin Diameter	E	2 1/2 in			3 in				
Spindle Ear Width	F	5 3/8 in			6 7/8 in				
Open Width	G	63 3/8 in	69 7/8 in	77 in	77 3/8 in	82 1/4 in	86 3/8 in	94 in	100 5/8 in

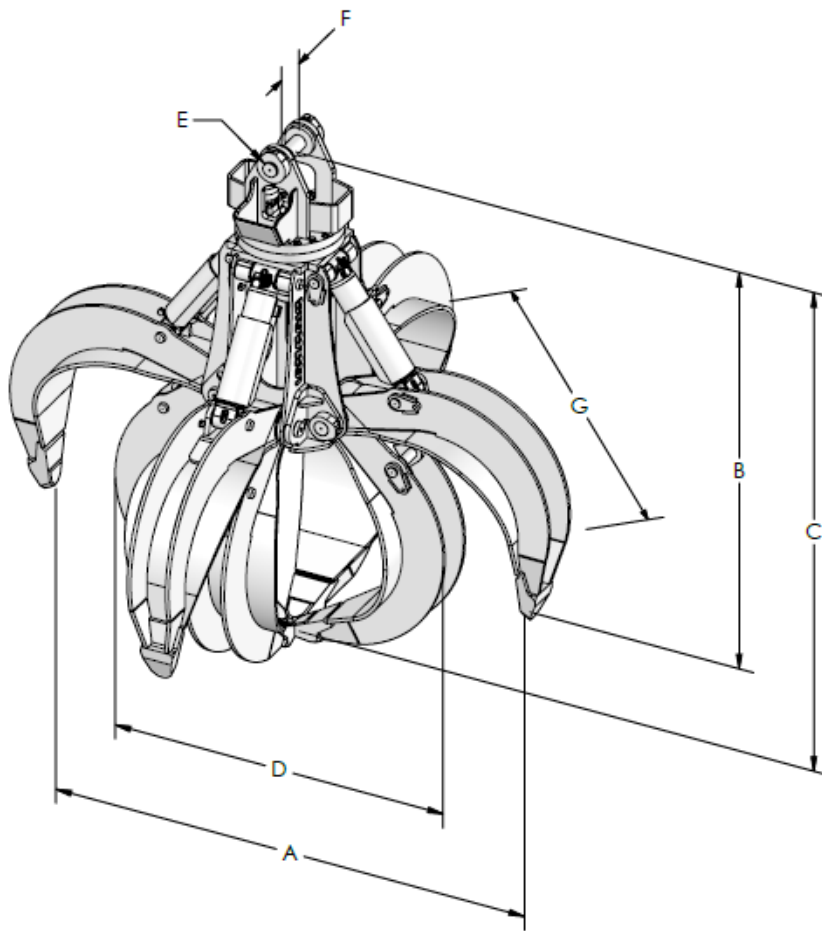

Optional Tine Reinforcement



Optional Magnet Bezel

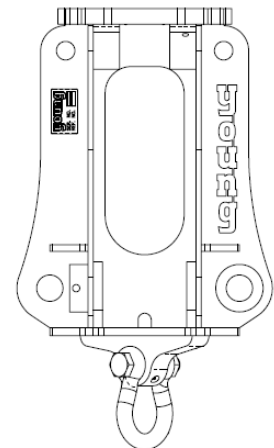

Optional Half-Way Up Enclosed Tines



Optional:

- Knock-Around Rotation
- Special Crossheads to fit OEM booms

www.youngcorp.com

find us on facebook