

young[®]

CORPORATION

MODEL RS

CLAMSHELL BUCKETS

Quality since 1902

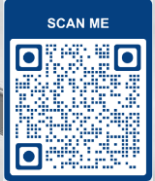

Young Corp. PO Box 3522, Seattle, WA 98124 (800) 321-9090
www.youngcorp.com

For loose materials up to 3500 lbs. per cubic yard

Models	Max. Machine Size	Capacity (cu yd)	Weight (lbs.)	A	B	C	D	E
RS-150DBE	135,000 lbs.	1 1/2	5,420	54	104	59 1/2	70 1/4	88
RS-200DBE	135,000 lbs.	2	6,280	59	111 1/2	64 1/2	78	97
RS-250DBE	135,000 lbs.	2.5	6,660	63	116 1/2	69 1/2	78 1/2	99 1/2
RS-300DBE	135,000 lbs.	3	6,950	67	120 1/4	73 1/2	79	101 1/2
RS-350DBE	135K - 200K lbs.	3.5	9,470	71	125 3/4	77	94 1/2	116
RS-400DBE	135K - 200K lbs.	4	9,770	73	129 1/4	80 1/2	95	117 3/4
RS-450DBE	135K - 200K lbs.	4.5	10,040	77	132 1/2	83 1/2	95 1/2	119 1/2
RS-500DBE	135K - 200K lbs.	5	10,310	80	135 1/2	86	95 3/4	121
RS-550DBE	200K - 300K lbs.	5.5	13,980	82 1/2	149 1/2	90	105 1/2	135 1/2
RS-600DBE	200K - 300K lbs.	6	14,320	84 1/2	152 1/2	92 1/2	105 3/4	137
RS-700DBE	200K - 300K lbs.	7	14,890	89 1/2	157 1/4	97	106 1/4	139 1/2

- Features power rotation and replaceable bolt-on cutting edges.
- Standard hardened pins and bushings to resist rust and long wearing.
- We also offer custom sizes, weld-on edges, blunt edges, lap seals, fixed or non-rotating head, underwater seal kit and height extensions for longer reach

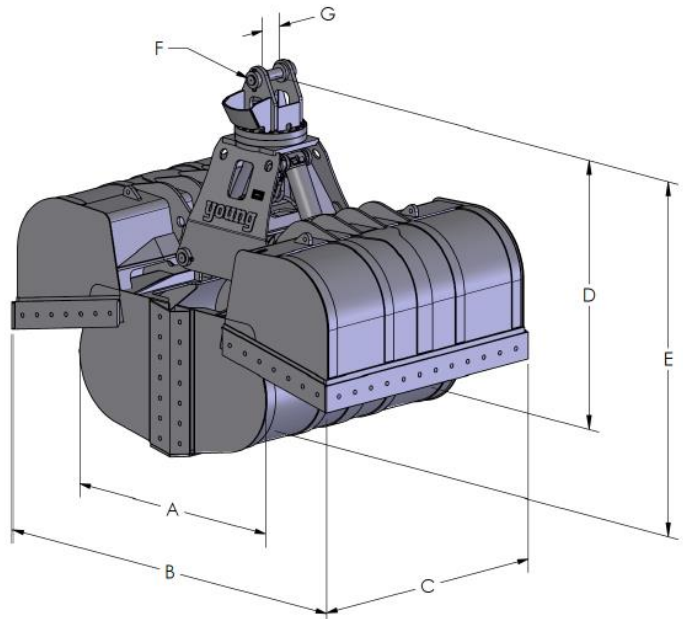

Quality since 1902