

## 3x2 GRAPPLES

An all purpose tool for handling loose scrap metal, car bodies, demolition debris and more. Features two opposing tines with multiple tips allowing the tines to bypass resulting in a tight squeeze on bulky materials and long objects.



**360-Degree Standard Power Rotation** is high torque and heavy duty

**High Pressure Rotary Union** reduces back pressure and extends seal life

**Heavy Duty Timing Link** maximizes clamping power.

**Weld-On Leg Tips** are designed to be durable and replaceable.

**High Pressure Hydraulic Cylinders** features thick barrel walls, large ports and bolt-on cylinder heads for easier maintenance.

**Cylinder Shrouds** protects cylinder walls and reduces material packing.

**Heat Treated Pins and Bushings** for extended wear

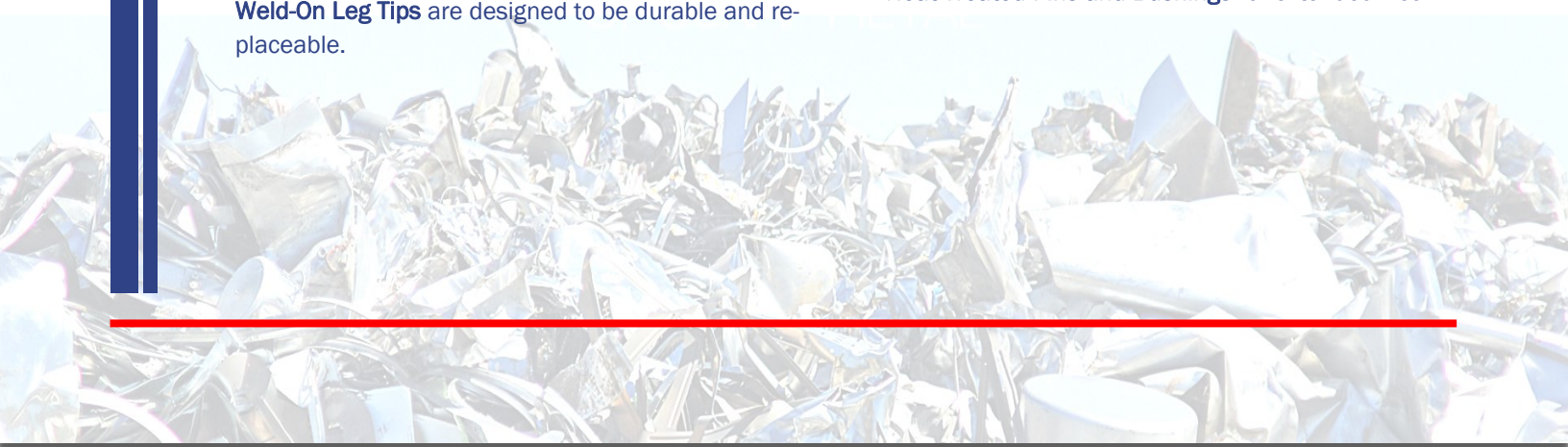

Max Machine Weight		65,000 lbs.	135,000 lbs.
Model		<b>LBG90</b>	<b>LBG100</b>
Tool Weight		3100 lbs.	5700 lbs.
Max Opening	<b>A</b>	90 in	102 in
Min Opening	<b>B</b>	19 in	21 in
Open Overall Height	<b>C</b>	64 in	70 in
Closed Overall Height	<b>D</b>	80 in	88 in
Inside Leg Height	<b>E</b>	25 in	27 in
Leg Width (3-Tip)	<b>F</b>	35 in	44 in
Leg Width (2-Tip)	<b>G</b>	20.5 in	30 in
Crosshead Width		6 in	8.25 in
Pin Diameter		2.5 in	3 in

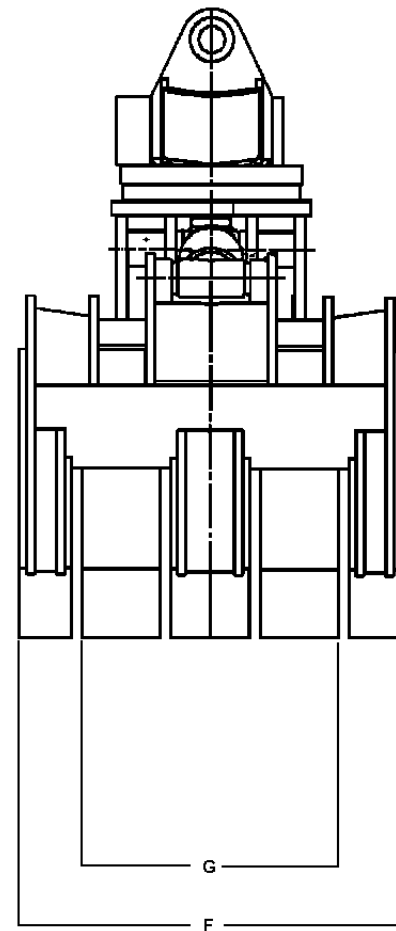
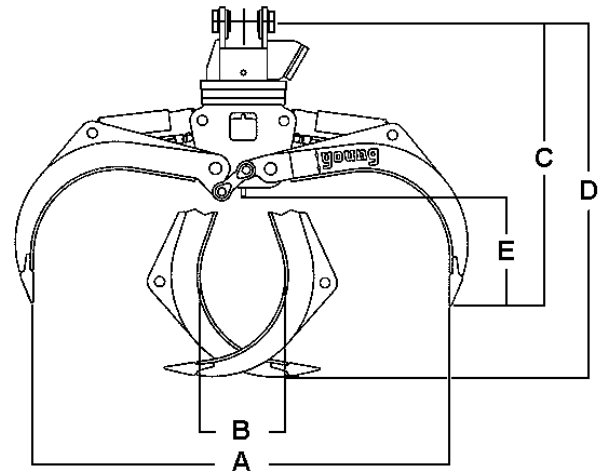

Optional:

- Special Crossheads to fit OEM booms

